

# ULTRAFLEX Installation instructions

- Do not start with installation before the material has reached core temperature between 10-25°C (50-77°F). Let the slats acclimate for at least 24 hours at the normal room temperature.
- During installation the house temperature must remain between 18-22° (64-72°F). (**normal room temperature**)

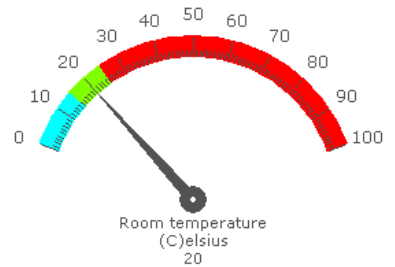

- If tools to be used to assemble the slats, **please use a rubber hammer only.**

- Make sure there is an **expansion gap (approx. 20-30 mm)** from the wall to the middle of the last support.

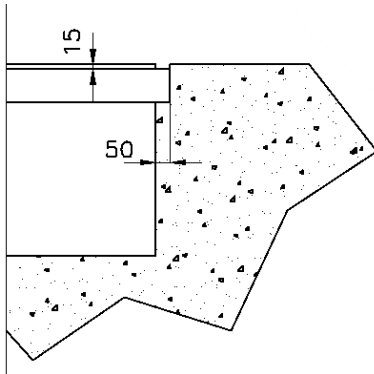
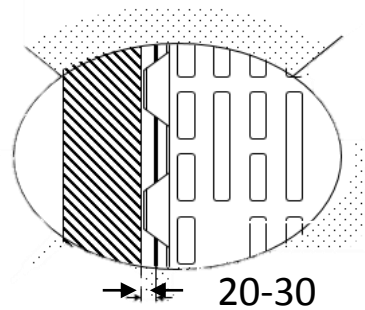

- Support beams require **50 mm wide support edge.**
- Ultraflex slats are 15 mm higher than the top of the beams

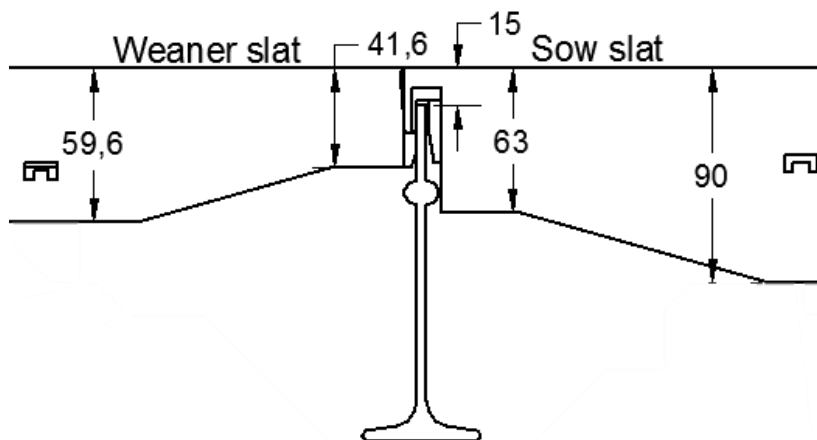

**IKADAN**  
SYSTEM